



	Ratings		
Maximum Voltage, rms	245kV	362kV	550kV
Physical Size			
Continuous Current	2000/3000/4000A, rms		
Short-time & Short-Circuit Current	31.5/40/50/63kA, rms		
Power Frequency One Minute Dry, rms	425kV	500kV	740kV
Switching Impulse Withstand Voltage (Open)	Not Required	825kV (peak)	1175kV (peak)
Full Wave Withstand Voltage, Peak	900kV	1050kV	1550kV
Rated Breaking Time	2 cycle		
CB Operating Mechanism (type/open/close)	BM-2/Spring/Spring		AM-38/Pneumatic/Spring
Disconnecting Switch Mechanisms	Motor		
Ground Switch Mechanisms	Manual/Motor		
Fast-Acting Grounding Switch Mechanisms	Motor Charged Spring		

Gas Switch and Circuit Breaker

The compact solution to expand your transmission substation

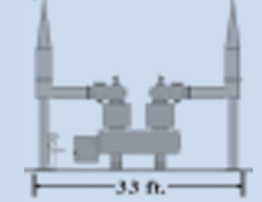

Mitsubishi Electric Power Products, Inc. Project Management and Local Support

Mitsubishi Electric Power Products, Inc. (MEPPI), located in Warrendale, PA, is responsible for all Mitsubishi Electric Corporation's transmission and distribution electrical equipment in North America. The primary point of contact between the North American customers and our factories in Japan is the MEPPI office. All technical and commercial communications are handled by the MEPPI Substation Department — a fully staffed group of project managers, project engineers, project drafters, project purchasing, and accounting as well as other functions. A factory field service engineer is present for installation supervision of the GSB. An application engineer is on staff to provide technical support, assist the project manager, make any necessary site visits, perform inspections, and handle customer's service requests.

**Mitsubishi Electric
Transmission and Distribution**

Mitsubishi Electric Power Products, Inc. (MEPPI) has been long known as the leading manufacturer of dead-tank high voltage Gas Circuit Breakers (GCB) in North America. Thousands of GCBs rated at transmission voltages from 72kV through 1100kV have been installed and are operating reliably on utility T&D systems. Introduced in 1974, the design is based upon demonstrated engineering principles in the use of SF6 gas insulation with extensive development and testing.

Limited Substation Space? No Problem.



MEPPI now introduces its latest evolution in circuit breaker technology, the Gas Switch and Circuit Breaker (GSB). Primary advantage of the GSB over the GCB is space savings at the substation. The GSB uses the same proven dead-tank circuit breaker, but replaces the switches you are using now with ones insulated by SF6. The space required for the breaker maintenance ground switches and disconnect switches is reduced dramatically. The resulting product replaces the standard combination of GCB and air switches and places the same functions into one-third the length.

Mechanical Assembly

The GSB features isolated phase dead tanks supported by a galvanized steel frame. Each tank houses a single-break, true puffer interrupter. The interrupters are interfaced through nozzles to the adjacent switches. Current transformers are mounted onto these nozzles. Conductors connect the circuit breaker through the nozzles to the maintenance ground switches and disconnect switches. The switches are then terminated by air bushings for connection to the line terminal or substation bus. The entire assembly is designed to fit in a space not much longer than the circuit breaker alone. Design of gas zones and positioning of access platforms are made with consideration for service and safety.

The disconnect and ground switches each have 4-inch diameter viewing ports on the sides of the enclosures. This insures a positive observation of contact switch positions prior to performing service on the breaker.

Current transformers and bushings are chosen to meet the specific application requirements. Fast-acting ground disconnect switches are also available for mounting on the assembly, each of which are also gas-filled and occupy a fraction of the space ordinarily required by air switches.

The breaker controls and switch interlocks are integrated in the local control cabinet positioned and installed in close proximity to the GSB. Local controls are provided, or optionally they can be marshaled into a central control facility for remote operation.

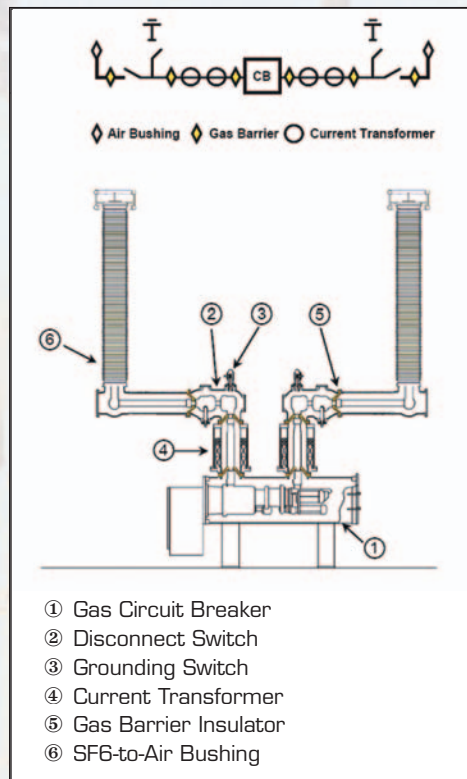

BM-2 Spring Operator (362kV & 245kV Models)

The BM-2 breaker operating mechanism is maintenance free by virtue of the following:

- (1) The mechanism casting frame has been hot dip galvanized, machined as required, and then electrostatically zinc plated.
- (2) All major components including trigger, latch, and others in the mechanism are stainless steel.
- (3) All gears and ratchet wheel surfaces are especially heat treated with a molybdenum disulfide compound to eliminate the need for cleaning or greasing in the field.
- (4) There is a grease bearing associated with the main shaft designed for a lifetime of use.
- (5) The torsion bars are made of high strength steel enclosed in a steel cylinder. (Providing maximum safety to personnel).

The power generated by the torsion bar assembly is equal to that developed by a pneumatic mechanism, but with far fewer parts. The reliability of this operating mechanism has been proven. It has been designed to last for 30,000 operations, three times longer than the industry standard.

The breaker equipped with the BM-2 operating mechanism is capable of O-CO without motor operation and O-CO-15s-CO-15s-CO...Continuing

with motor operations (repeat CO every 15 seconds with motor operations). The charging of the motor requires 10 seconds of running at 100% control voltage.

Self Diagnostics

Each GSB has self-contained gas monitoring systems located on each zone of each phase of the product. The precise yet simple arrangement of the system eases evacuation, filling, inspection, and monitoring while increasing safety. Because there are few components in the monitoring system, the chances of mal-operation or failure causing false alarms are minimized. And by using the fewest possible seal points in combination with low static pressure, potential leak paths are greatly reduced.

Mitsubishi Electric's strong commitment to environmental responsibility has enabled them to become the leader in low emissions manufactured T&D equipment. This is accomplished first by paying careful attention to exact machining specifications and critical tolerances for each metallic surface. Transition points are dimensionally arranged to contact with minute tolerances insuring near perfect geometric edges resulting in an extremely tight fit. Static systems implement an "O" ring as the primary seal. A silicon seal, beyond this primary seal, prevents outdoor corrosive elements from impacting the seal or machined surfaces for the life of the equipment.

Features of the GSB Design

Electrical parts:

1. Integral NEMA 4-hole bushing terminals
2. Porcelain or Polymer bushings available
3. Verified full dielectric and interrupting rating at lockout pressure
4. Contacts easily accessible for inspection and servicing

Mechanical Operation:

1. Spring/Spring or Pneumatic/Spring no-leak mechanisms
2. Universal AC/DC spring charge motor
3. Quick Spring Charging for O-CO-15s-CO Duty Cycle

Insulation:

1. Dead-tank construction
2. Available in 40kA, 50kA and 63kA interrupting ratings

Flexibility

1. Application without Tank Heaters to -30 degrees C
2. Definite purpose capacitive current switching capability
3. Reactor switching capability
4. Tested for high-seismic demand applications

Performance

1. Tested and verified for 90% of shortline fault rating
2. Tested and verified to exceed ANSI standards



145kV Gas Circuit Breaker

Case Study

A northeastern utility was recently required by its ISO to draw additional capacity from transmission lines to compensate for the scheduled decommissioning of an aging generation site. Protection for new cables and voltage conditioning equipment was to be fit into an existing transmission substation. GCB and air insulated switches as well as accompanying equipment exceeded the space available within the substation fence. Upon investigation the expansion of these boundaries would have taken longer than the ISO was allowing for the transfer of the load off of the generation facility.

The GSB solution was fit inside the existing dimensions of the substation without the need of expanding its boundaries. As a result, the utility installed GSBs within the space available, avoiding the time to permit an expansion.

