

## *SF6 Gas Insulated Substations*



**Mitsubishi Electric** is a world leader in the supply of SF6 Gas Insulated Substations (GIS), having supplied well over 10,000 circuit breaker positions of GIS since 1968. In particular, **Mitsubishi Electric Power Products, Inc. (MEPPI)**, a wholly-owned subsidiary of **Mitsubishi Electric** dedicated solely to serving the North American market, has supplied over 350 circuit breaker positions of GIS in the U.S. alone since 1981.

**Mitsubishi Electric** has provided many technological developments for GIS, including supplying the world's first 550kV GIS in 1976, and the world's first 1,100kV GIS in 1994. **Mitsubishi Electric** continues to advance technology and introduce new developments for the GIS of the future.

The basic technology of the **Mitsubishi Electric** GIS comes from our vast experience in supplying dead-tank type SF6 gas circuit breakers. The design of our gas circuit breakers has been consistently refined since the initial **Mitsubishi Electric** gas circuit breakers were developed. We have supplied more than 30,000 sets of gas circuit breakers since 1965. This experience has allowed us to develop and supply the highest quality, most reliable gas circuit breakers for applications all over the world.

Some of the advantages that the **Mitsubishi Electric** gas circuit breakers provide are:

- ◆ Ability to interrupt out-of-phase short-circuits.
- ◆ Ability to interrupt short-line faults.
- ◆ Overvoltage is kept to a minimum.
- ◆ Low noise operation.
- ◆ Minimum gas leakage (less than 0.1% per year).
- ◆ High reliability.
- ◆ Minimal maintenance requirements.

A GIS has many advantages over a conventional substation, including a space saving and flexible design, less field construction work resulting in quicker installation time, reduced maintenance, higher reliability and safety, and excellent seismic withstand characteristics. Aesthetics of GIS are far superior to that of a conventional substation, due to its substantially smaller size. A GIS can even be installed in a building, if desired. When all of these advantages are taken into consideration, a GIS is a cost effective alternative to a conventional substation that offers many benefits to the end user.



**MEPPI** offers the expertise and experience to provide complete turnkey responsibility for a GIS project. We have successfully completed a large number of greenfield, retrofit and replacement projects. **MEPPI** has a fully staffed substation division at our Warrendale, PA facility that is dedicated to providing project engineering and project management support for such turnkey GIS projects. We are able to design custom equipment layouts that offer innovative solutions to obstacles encountered with each new project, providing an end product that best meets the needs of each particular customer.

**Mitsubishi Electric** strives to offer high quality, innovative products. Our GIS provides an excellent solution to the problem of limited space availability, and provides a highly reliable product that will provide trouble-free operation for many years.



# GIS INQUIRY FORM

To: **National Sales Manager - Substation Division**  
**Mitsubishi Electric Power Products**  
Fax: 724-778-5209; Tel: 724-772-2555  
E-mail: [ssd-sales@meppi.com](mailto:ssd-sales@meppi.com)

Date: \_\_\_\_\_

Customer Name: \_\_\_\_\_

Address: \_\_\_\_\_

City, State, Zip: \_\_\_\_\_

Telephone: \_\_\_\_\_ e-mail: \_\_\_\_\_

Information need by (date): \_\_\_\_\_

Information needed:           Footprint  Layout drawing  Budget price

## **1. APPLICATION DATA**

Rated Maximum Voltage (kV): \_\_\_\_\_

Interrupting Rating (kA): \_\_\_\_\_

Continuous Current (A): \_\_\_\_\_ (GIS)

Continuous Current (A): \_\_\_\_\_ (Main Bus)

Continuous Current (A): \_\_\_\_\_ (Line)

Continuous Current (A): \_\_\_\_\_ (Xfmr)

Number of Breakers: \_\_\_\_\_

Indoor/Outdoor: \_\_\_\_\_

Seismic (Y/N): \_\_\_\_\_

Any other special considerations/notes: \_\_\_\_\_

Customer/Owner: \_\_\_\_\_

Location: \_\_\_\_\_

Project Name: \_\_\_\_\_

Delivery Date: \_\_\_\_\_

Energization Date: \_\_\_\_\_

Turnkey/Equipment Only: \_\_\_\_\_

Bus Configuration: \_\_\_\_\_

(ex. Ring, BAAH, DB-DB, DB-SB, SB, M&T, other)

Ambient Temp (Min/Max): \_\_\_\_\_

## **2. ONE LINE SCHEMATIC**

*Please use another sheet if necessary.*

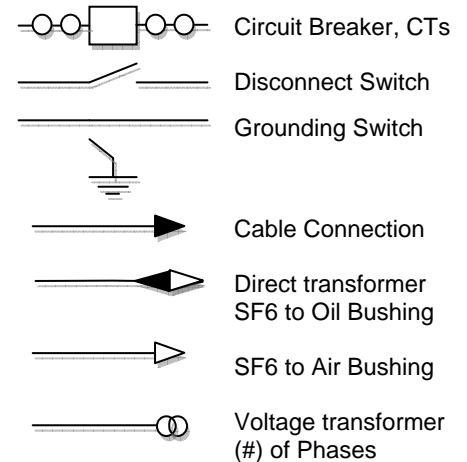

## **3. SITE DIMENSIONS OR SHAPE, LOCATION OF INCOMING/OUTGOING LINES.**

*Please use another sheet if necessary.*

By MEPPi:  
Negotiation #: