

Seattle Iron & Metals Corp. D-STATCOM Project



Project Highlights

- **Ratings**
 - 0 to +5 Mvar Dynamic Range VSC
 - Overload Rating of 150 %
 - 4.16 / 26.4 kV-ac
- **VSC Based Design**
 - Voltage Sourced Converters with Insulated Gate Bipolar Transistor (IGBT) Elements in Outdoor Weatherproof Enclosure
- **Voltage Flicker Suppression**
 - Dynamic Voltage Control of Shredder Motor for Steel Recycling Operation
- **Air-Cooling Method**
 - Low-Loss Forced Air Cooling System
- **Commissioned**
 - January 2000

Seattle Iron & Metals Corp. D-STATCOM Project



The Seattle Iron & Metals D-STATCOM System is applied for voltage flicker suppression of a large 4000-hp shredder motor for steel recycling operation. The D-STATCOM System consists of 5 sets of IGBT-based Voltage Sourced Converters, interconnecting step-up transformer, and a parallel capacitor bank. The converters have a rated output capacity of +/-2000 kvar continuous, with a one-minute 150% overload rating to +/-3000 kvar. The total system is designed such that it can control reactive power from 0 to +5000 kvar in combination with the converters and the capacitor banks of both the shredder motor and the D-STATCOM system.

The main objectives of the D-STATCOM are as follows:

- Voltage Flicker Suppression
- Power Factor Control
- Voltage Stabilization of the interconnecting Utility's 4.16 kV / 26.4 kV Network

The D-STATCOM converters implement an advanced, high-speed control technology for dynamic reactive compensation, resulting in improved distribution system power quality.

Photos:

Front page; External View of the IGBT-Based D-STATCOM Converter Panels

Left top; View of D-STATCOM System in the Seattle Iron & Metals Steel Recycling Facility

Left Bottom; Single-Line Diagram of the Seattle Iron & Metals Corp. 5 Mvar, 4.16 kV D-STATCOM System and Application

Seattle Iron & Metals Corporation 5 Mvar, 4.16 kV D-STATCOM System

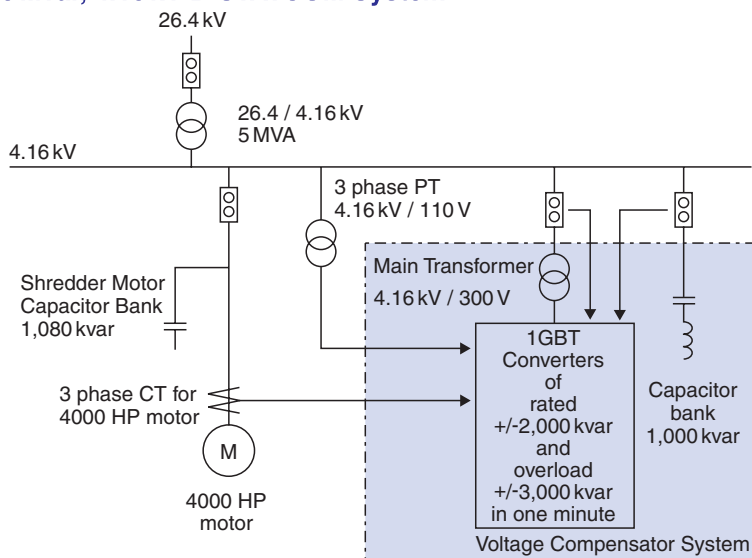

Project Name	Seattle Iron & Metals Corporation D-STATCOM System Project
Commissioned	January 2000
Location	Seattle, Washington, USA
Dynamic Rating	0 to +5 Mvar
System Voltage	4.16 / 26.4 kV-ac
Converter Type	2-Level Voltage Sourced Converter Design
Configuration	5 Converter Sets in Parallel
IGBT Ratings	1.2-kV / 600-A
Control	High Frequency Control for Flicker Suppression Application

TMT&D

TMT&D Corporation

TMT&D Corporation
12-1 Toranomon 3-Chome, Minato-ku,
Tokyo 105-0001 Japan
Homepage: www.tmt-d.com

MITSUBISHI ELECTRIC POWER PRODUCTS, INC.
530 Keystone Drive -HQ Building
Warrendale, PA 15086 USA
Telephone: 724-778-5111
Homepage: www.meppi.com

[Other locations]
ARGENTINA, AUSTRALIA,
BRAZIL, CHINA, HONG KONG,
INDIA, KUWAIT, SAUDI ARABIA,
SINGAPORE, TAIWAN, U.A.E., U.K.

Printed in Japan

30612-1 03-09E20

•The data given in this catalog are subject to change without notice.